

92-97 4R70W repin for using 98-08 trans:

In 98 the hard connector replaced the internal wire harness...and a repin or solenoid swap is required. The following info is regarding a repin of the 92-97 chassis harness.

Note there will be 2 extra LIVE 12+ wires that will need to be cut and wrapped into the harness, or pinned to unused ports in the connector.

Here is the factory diagram looking INTO the chassis connector.

1992-1997

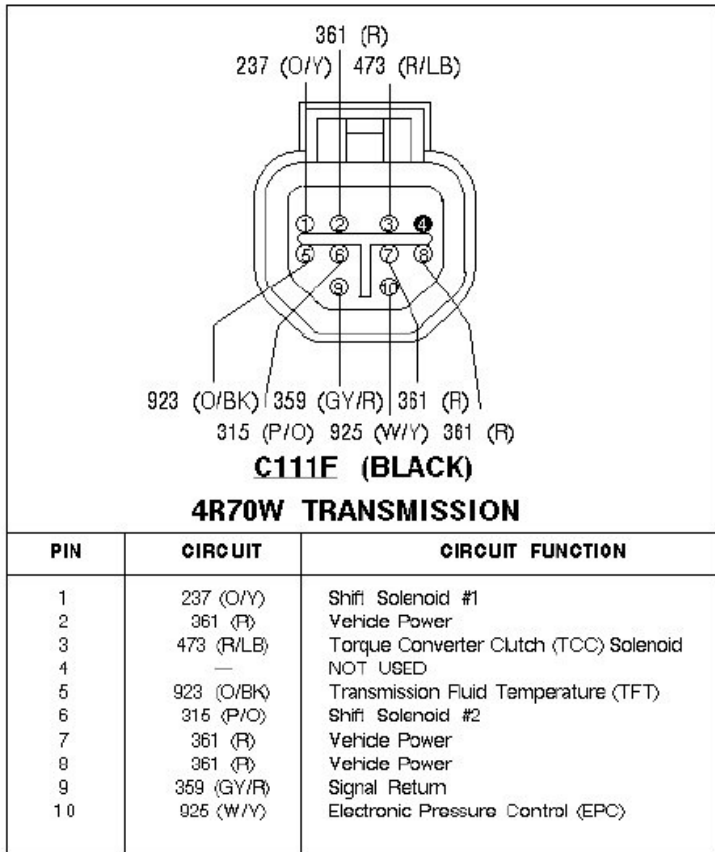

1998-2005

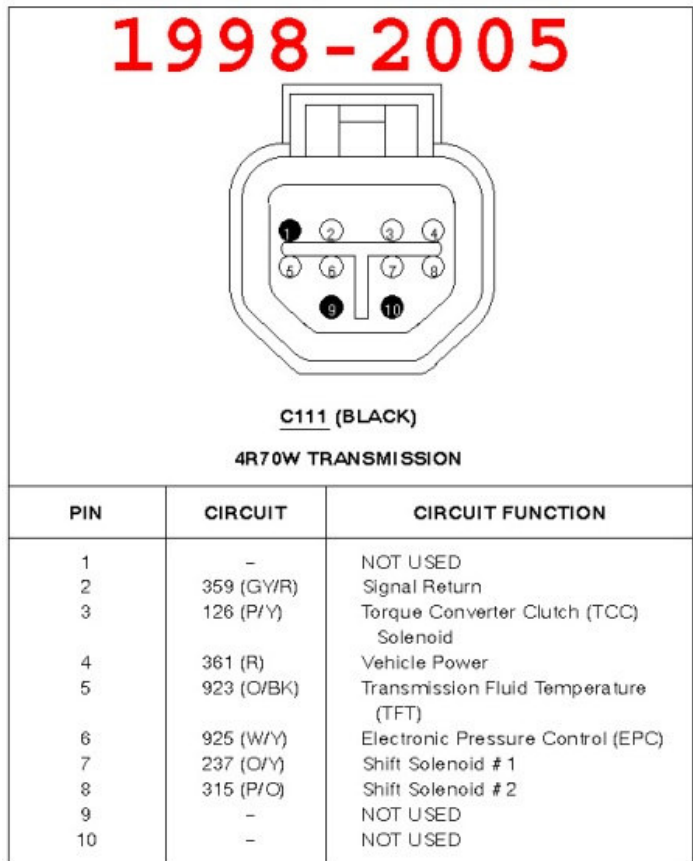

Here is the repin instructions in text:

In the 92-97 chassis harness connector, using small screw driver, disassemble the connector all the way down to the internal rubber insulator. Remove and place these wires...color can vary, so I describe in terms of position.

-
- 10 to 6
- 9 to 2
- 8 to 10 or leave out
- 7 to 9 or leave out
- 6 to 8
- 5 no change
- 4 in blank now, put 2 here
- 3 no change
- 2 to 4 (12v+)
- 1 to 7

